



MivaLife
Hardware
User Manual





Note: This manual applies to several packages. As such, some parts and some steps may not pertain to the package that you purchased.





Contents

TripleShield At A Glance	3
Assemble MivaShuttle And Connect To Router.....	5
Set Up And Power Up IP Camera	7
Place Sensors And Power Up Siren	10
a.) Install the Door/Window Sensor	10
b.) Motion Sensor.....	13
c.) Siren	16
Appendix A	18
☐ MivaShuttle	18
☐ Flash Drive	19
☐ Camera.....	19
☐ Door/Window Sensor	20
☐ Motion Sensor.....	21
☐ Siren.....	22
☐ Remote Control	23
Appendix B	24
FCC Statement.....	25

TripleShield At A Glance

Item	Product Name	Function
	<p>MivaShuttle (control unit)</p>	<p>Provide wireless access and control function of mi Security system</p>
	<p>IP Camera</p>	<p>Smart camera with an Adjustable Motion Detection Feature and infrared night-vision with a built-in microphone</p>
	<p>Motion Sensor</p>	<p>Detects and alerts user of movement using infrared technology and a 120-degree angle of coverage</p>
	<p>Door/Window Sensor</p>	<p>Alerts system when door or window is opened</p>

V 2.3.0

	<p style="text-align: center;">Siren</p>	<p>First line of defense for fending off an intruder</p>
	<p style="text-align: center;">Remote Control with Panic Button</p>	<p>Wirelessly Arms or Disarms system with built-in emergency panic button function</p>
	<p style="text-align: center;">16G Flash Drive</p>	<p>Data storage for video recordings</p>

Warning:

Do not dispose of electrical appliances as unsorted municipal waste. Use separate collection facilities. Contact your local government for information regarding the collection systems available.

Assemble MivaShuttle And Connect To Router **1**

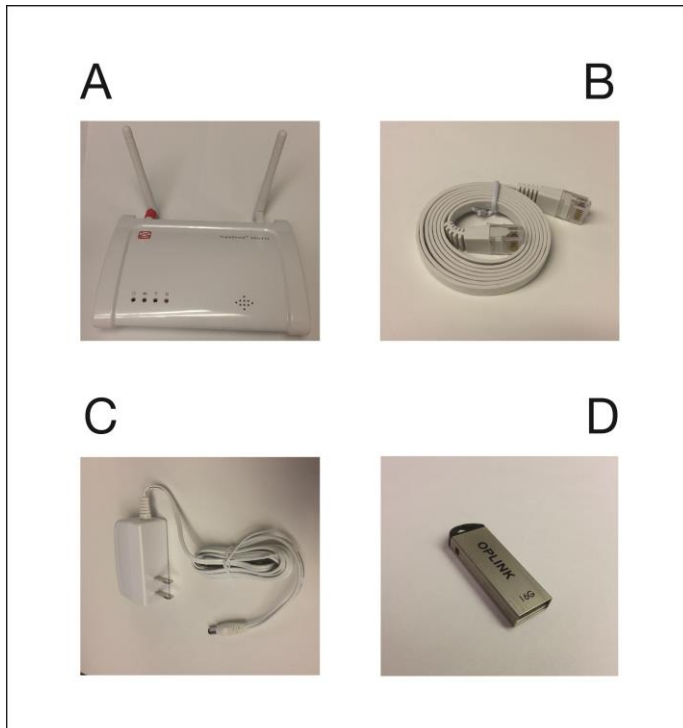

Contents

- A. MivaShuttle
- B. Ethernet Cable
- C. Power Adapter
- D. 16G Flash Drive

Overview Features

- Smart setup wizard
- Bridge the communication for all Oplink smart devices
- Provide wireless access and control function of MivaLife system
- MivaShuttle allows for system recovery
- Transmit sensor data and control signal
- Support MivaTek cloud server

Wireless Features

- Support IEEE 802.11 b/g/n standards
- Wired and Wireless Network Support
- Security Support: WPA2-PSK encryption

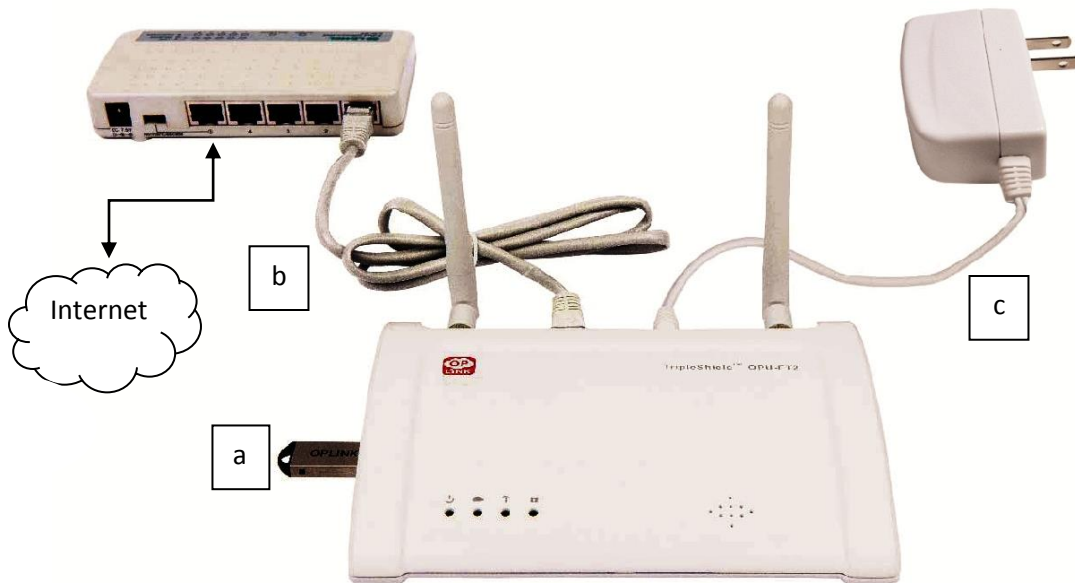

MivaShuttle Installation with Flash Drive

- a. Plug the Flash Drive into the MivaShuttle.
- b. Connect the MivaShuttle to the home router using the provided Ethernet Cable.
- c. Plug Power Adapter to the MivaShuttle and an outlet.
- d. Enable router's DHCP setup (see Appendix B for DHCP setting of router).

****Most routers have their DHCP setting set to "Enabled" by default.***

Set Up And Power Up IP Camera 2



Contents

- A. Camera
- B. Bracket
- C. Power Adapter
- D. Mounting Screws And Dry Wall Anchors

Overview Features

- Smart setup wizard
- High quality video
- Built-in antenna and microphone
- Support MivaTek cloud server
- Day/night vision
- Records automatically when events are triggered
- Remote monitoring from smartphone or tablet

Wireless Features

- Supports IEEE 802.11 b/g/n standards
- Wired and Wireless Network Support
- Security Support: WPA2-PSK encryption

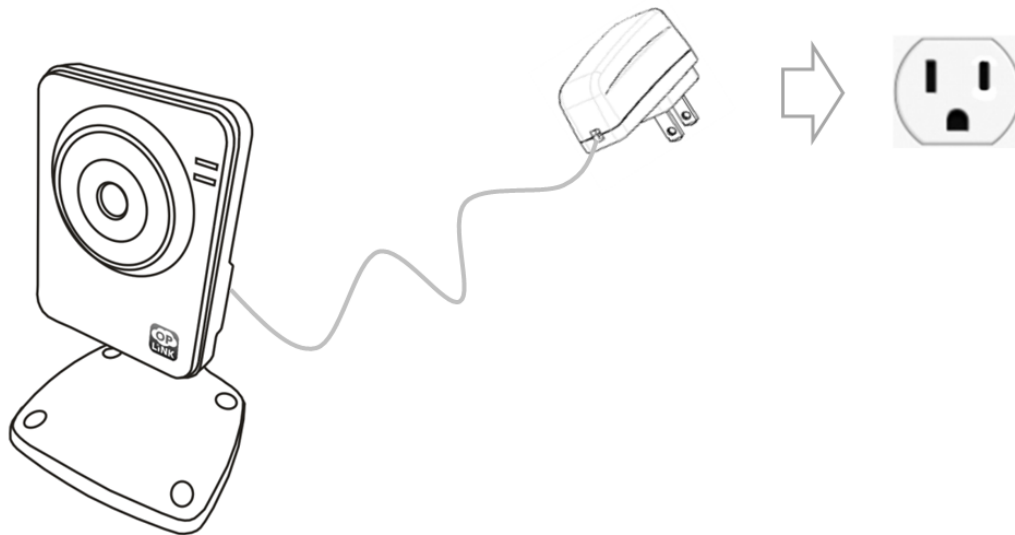

Camera Installation

Set Up the Camera

- a. Place the Camera within 5 feet of the MivaShuttle to establish connection.
- b. Connect power adapter to the Camera.
- c. Connect power adapter to an outlet (top LED will turn on and display solid amber).
- d. The bottom LED will turn on and display blinking green when a WiFi connection has been established.
- e. Once the Camera is connected and working, it can be moved to its desired location.

Mounting the Camera (Optional)

Note: The Camera can be moved and mounted after the initial activation. The Camera can be placed on a table using the attachment base provided. We recommend you placing the Camera on a countertop giving it a clear line of sight. Infrared night vision makes it easy to monitor at night.

Step 1: Install camera attachment base



V 2.3.0

- a. At the desired camera mounting location, secure the Camera attachment base to the wall using the provided screws.
- b. Make use of the provided screw anchors if necessary.

Step 2: Mount the Camera

- a. Screw Camera onto attachment base.
- b. Secure Camera using attachment base nut.

Step 3: Complete the Camera's mount

- a. Make sure the Camera is firmly fixed on the wall.
- b. Adjust the Camera to the preferred position.

Place Sensors And Power Up Siren..... 3

a.) Install the Door/Window Sensor



Contents

- A. Sensor Kit (2 pieces, 1 large unit [sensor] and 1 small unit [magnet])
- B. Batteries
- C. Double-sided Tape

DWM1301 Overview Features

- Smart setup wizard
- Wireless security technology
- Support MivaTek cloud server
- Apply to doors, windows, etc.
- Send off instant intrusion alerts
- Easy to install, no wiring required
- Auto add-on to any MivaLife security system
- Battery Included
- Tamper Switch
- Low Battery Alert Notification

V 2.3.0



Battery Installation

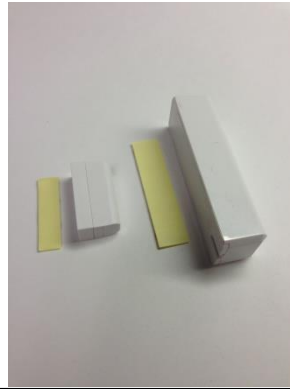

Apply Double-Sided Tape



Magnet/Sensor Positioning

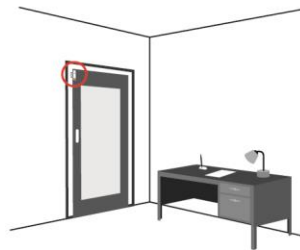

Mount Door Sensor



Mount Window Sensor

Sensor DWM1301 Installation

To install the sensors:

1. Each Door/Window Sensor set consists of two pieces. Take the larger piece and with slight force, push the small tab on the back plate outward and slide the back plate upward. Remove the back plate and insert a battery into each Door/Window Sensor set.
2. Apply the double-sided tape to the backs of each piece.
3. Door/Window (It is recommended that the Door/Window Sensor be mounted in a vertical/upright position.)
 - a. On your door:
 - i. After selecting a location on the door, preferably on the edge of the door away from the hinges, the large unit of the sensor should be placed on the immovable frame of the door.



V 2.3.0

- ii. Place the small unit on the movable door with the small unit aligned near the top half of the large unit and not exceeding the recommended width of a pencil or a quarter of an inch between the sensors for best performance.
 - iii. The spacer is used in situations where the smaller piece needs to be elevated to the larger piece to ensure proper contact.
 - b. On your window:
 - i. After selecting a location on the window, the large unit of the sensor should be placed on the immovable window frame.
 - ii. Place the small unit on the movable window with the small unit aligned near the top half of the large unit and not exceeding the recommended width of a pencil or a quarter of an inch between the sensors for best performance.
 - iii. The spacer is used in situations where the smaller piece needs to be elevated to the larger piece to ensure proper contact.
4. When you open and close the doors and windows, the two parts should separate when opened and then come back together when closed.
5. Verify that the two pieces are functional by noting that the LED on the sensor piece blinks on/off when the parts are separated. The LED on the sensor piece blinks on/off again when the parts are placed together again.

****Note: If your door or window does not allow you to properly place the large unit of the sensor on the frame, it is acceptable to place the smaller unit of the sensor on the frame to make the placing easier. This is an acceptable approach to sensor placement, although it should only be used when necessary.***

b.) Motion Sensor



Contents

- A. Motion Sensor
- B. Battery
- C. Double-sided Tape

Overview Features

- Smart setup wizard
- Wireless security technology
- Support MivaTek cloud server
- Detects motion up to 120-degree, 10-40 feet
- Passive Infrared, Pet immune
- Battery included
- Tamper Switch
- Low Battery Alert Notification
- Two Modes: Initial Test Mode and Power-Save Mode

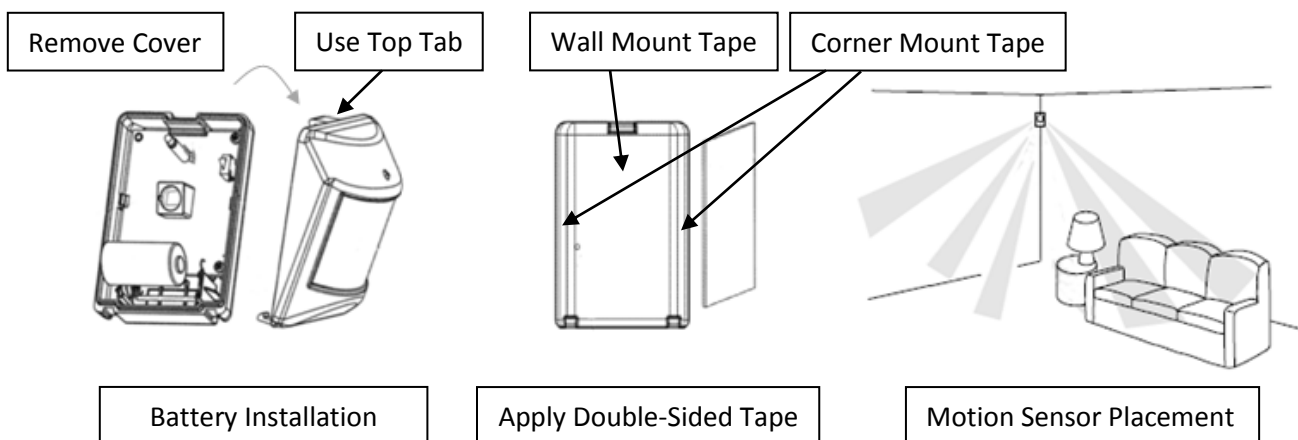

Motion Sensor Installation



V 2.3.0

Set up and wall-mount the motion sensor

Step 1: Insert Battery

- a. Lift top tab on cover to release and remove cover.
- b. Insert the battery noting the polarity (CR123A), and replace the cover onto the sensor.

Step 2: Install Motion Sensor

- a. Place the motion sensor appropriately to ensure maximum coverage of a monitored area. The motion sensor monitors any movement up to 35 feet away and should not be placed higher than 7 feet from the floor.
- b. For maximum coverage, it is recommended that the sensor be placed in the corner of the room to be monitored.
- c. Use the larger piece or the two thin pieces of double-sided tape to mount the motion sensor at the desired location on the wall or corner of the room.
- d. Make sure the motion sensor is placed at an angle with the least amount of obstruction for best coverage.
- e. The sensor is most effective in areas such as hallways and entry points where intruders will have to pass through.

3-Minute Cool Down Period

A 3-minute cool down period is programmed into the Motion Sensor. This helps reduce false alarms and prolongs battery life. After the most recent event has been triggered, the next motion detected by the sensor can happen only after the 3-minute countdown has elapsed. When/if motion is detected within the cool down period, the 3-minute countdown will restart.

Initial Test Mode and Power-Save Mode

The Motion Sensor has 2 modes: Initial Test Mode and a Power-Save Mode.

- The **Initial Test Mode** occurs during the first hour after a battery is put into the device, as is the case during the initial installation of the system. Within this hour, whenever the Motion Sensor



V 2.3.0

detects motion, the LED will blink. This demonstrates that the sensor is working. LED flashing during this hour does not always mean that an event has been triggered because of the 3-minute cool-down period programmed into the sensor.

- The **Power-Save Mode** starts after the first hour of installing a battery. The LED will blink only when the Motion Sensor detects motion and when the motion is not within the programmed 3-minute cool-down period.

***Notes:**

- *Do not aim the detector at a staircase which a pet has access to.*
- *Do not mount the detector near furniture or object higher than 4 feet tall which a pet may climb onto (such as a couch within 6 feet of the motion sensor).*

c.) Siren



Contents

- A. Wireless Siren With Power Adapter
- B. Mounting Screws And Dry Wall Anchors

Overview Features

- Smart setup wizard
- Wireless security technology
- Support MivaTek cloud server
- Alarm for 60 seconds upon receiving SIREN ON order, stops immediately upon receiving SIREN OFF order
- Pre-Installed Backup Battery

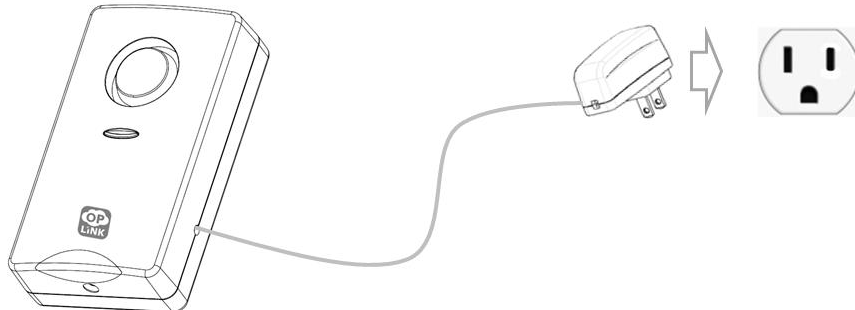

Siren Installation

Set Up the Wireless Siren

- a. Place the Siren within 5 feet of the MivaShuttle to establish connection.
- b. Connect power adapter to an outlet.
- c. Once connection has been established and working, the Siren can be moved to its desired location.



V 2.3.0

- d. The Siren comes with pre-installed backup batteries. To make use of the backup batteries, pull and remove the clear plastic strip to initiate battery contact.

Mount the Wireless Siren

- a. Use double-sided tape or screws to mount the Siren at the desired location.
- b. Connect Siren to nearest power outlet.

Appendix A

Specifications

📌 MivaShuttle



Model : OPU2120

Dimensions: 159.1 mm x 120 mm x 35.5 mm

Operating Temperature: 32° F to 113° F (0° C to 40° C)

Frequency: 2.4-2.4835 GHz

Transmit Speed: 150Mbps (Max)

Channel: 13

TX Power: 13dbm, 15dbm(Max)

Storage Temperature: -40° F to 158° F (-40° C to 70° C)

Network Protocols: DHCP, Auto IP Address

Network Interface: One 10/100Mbps LAN/WAN
Interchangeable Port,
IEEE 802.3 / IEEE 802.3u

Wireless interface: Wi-Fi, RF433MHz, WPA2-PSK

Power Adapter: 5V 1.5A

V 2.3.0

Flash Drive



Model: UST1100

Dimensions: 34.6 mm x 12.2 mm x 4.5 mm

Weight: 4.6g

Capacity: 16G

Communication Standard: USB 2.0

Performance: Read:20MB/sec above
Write: 4.5MB/sec above

Operating Voltage: 4.5-5.5VDC

System: Windows/Mac OS

Operating Temperature: 32° F to 113° F (0° C to 45° C)

Storage Temperature: -4° F to 158° F (-20° C to 70° C)

Camera



Model: IPC1200

Dimensions: 73(L) x 26(W) x 95mm(H)

Operating Temperature: 32° F to 113° F (0° C to 45° C)

Video compression: MJPEG

Image resolution: 640 x 480

Storage Temperature: 5° F to 140° F (-15° C to 60° C)

Network Protocols: DHCP, Auto IP Address

Network Interface: 1 Ethernet 10/100BaseT (RJ45) LAN
connection

Wireless interface: IEEE 802.11 b/g/n, WPA2-PSK

Power Adapter: 5V,1A

🔽 Door/Window Sensor



Model: DWM1300

Operating Temperature : 32° F to 113° F (0° C to 45° C)

Frequency: 433.80MHz – 434.1-MHz

Modulation: ASK

Transmit Power: > -51dBm(Manufacture's test condition)

Detection Type: Magnetic separation trigger function

Magnet Sensor Gap Activated: ~11mm (Reference)

Power source: 1.5V*2pcs“AAA” Lithium and Iron
Disulfide battery

Standby Current: <10uA (@3.3VDC)

Operating Current: <18mA (@3.3VDC)

Battery Low Level Indicator: 2.2V-2.4V

Low Battery Alarm Mode: Low battery alarms only when
another sensor alarm is triggered

Unpick Detection: Tamper switch wireless alarm



Model: DWM1301

Operating Temperature: 32° F to 113° F (0° C to 45° C)

Frequency: 433.92MHz +/-150KHz

Modulation: ASK

Transmit Power: >= -16dBm(Manufacture's test condition)

Detection Type: Magnetic separation trigger function

Magnet Sensor Gap Activated: ~25mm (Reference)

Power source: CR123A 3V

Standby Current: <3uA

Operating Current: <=15mA

Battery Low Level Indicator: 2.1 V-2.35V

Low Battery Alarm Mode: Low battery alarms only when another sensor alarm is triggered

Unpick Detection: Tamper switch wireless alarm

➤ Motion Sensor



Model: PIR1301

Operating Temperature: 14° F to 122° F (-10° C to 50° C)

Frequency: 433.92 MHz +/- 150KHz

Transmit Power: >= -16dBm(Manufacture's test condition)

Modulation: ASK

Power Source: CR123A 3V

Standby Current: <25uA

PIR Trigger Current: <=15mA

Power Consumption: 1 year (Triggered twice a day)

Battery Low Level Indicator: 2.1 V-2.35V

Low Battery Alarm Mode: Low battery alarms only when sensor alarm is triggered

PIR Trigger Alarm: Once the Motion Sensor is triggered, it will start a 3-minute countdown, and restart if any movement is detected within this period. The next event will be triggered only when no movement is detected within the 3 minutes.

Unpick Detection: Tamper switch wireless alarm

↘ Siren



Model: SRN1300

Operating Temperature: 32° F to 113° F (0° C to 40° C)

Device Type: Wireless Indoor Siren

RF Receiver Frequency: 433.92 MHz +/- 0.125MHz

Sensitivity: -110dbm

Modulation: ASK

Power Source: Main Power-AC Adaptor (American Standard);
Backup Battery-Alkaline "AAA"size * 3pcs

Standby Mode Current: ≤12mA(average)@4.5V

Alarm Mode Current: <=300mA@4.5V

Alarm Sound Level: $\geq 110\text{dB}@30\text{cm}$ on desktop 4.5V Power

➤ Remote Control



Model: RMC 1301

Power: CR2032, 3V Battery

Power Consumption: $>1\text{year}$ (Triggered twice a day)

Button: "ARM", ARM ON mode
"DISARM", ARM OFF mode
"Emergency", Panic Button

Operating Environment: 32° F to 113° F (0° C to 45° C)

Storage Temperature: -4° F to 140° F (-20° C to 60° C)

RF Frequency: 433.92 MHz +/- 150 KHz

Modulation: ASK

Transmit Power: $\geq -10\text{dBm}$ (manufacturer's test condition)

Appendix B

DHCP (Dynamic Host Configuration Protocol) setting of router

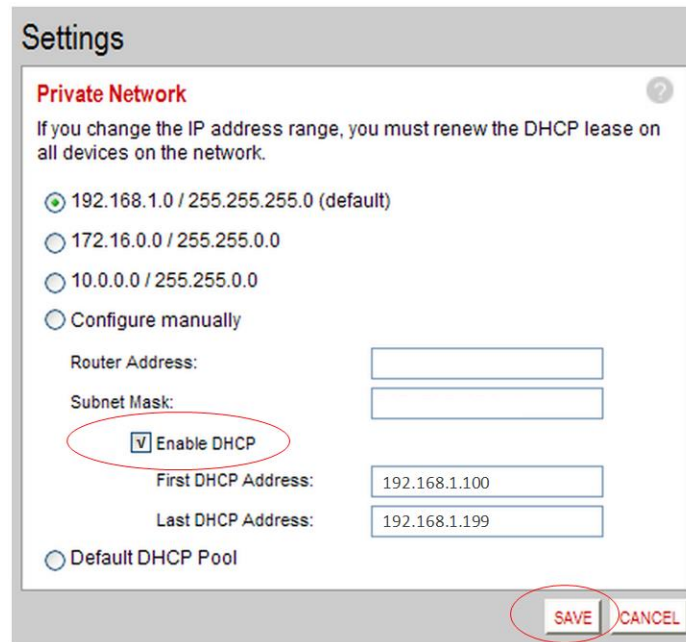

Fig.1 DHCP Setting of Router (Example of Router: 2wire 2701HG-B)

- (1) Open a browser and enter your IP address, such as "192.168.X.X". You can find this address on the back of the router.
- (2) Log in to your router's account. Check your user manual or documentation if you do not know the log-in credentials.
- (3) Make sure you are in the Setup category, select 'Enable DHCP' and enter the address range (from "192.168.1.100" to "192.168.1.199").



V 2.3.0

FCC Statement

1. Warning: Changes or modifications to this unit not expressly approved by the party responsible for compliance could void the user's authority to operate the equipment.

NOTE: This equipment has been tested and found to comply with the limits for a Class B digital device, pursuant to Part 15 of the FCC Rules. These limits are designed to provide reasonable protection against harmful interference in a residential installation. This equipment generates, uses and can radiate radio frequency energy and, if not installed and used in accordance with the instructions, may cause harmful interference to radio communications.

However, there is no guarantee that interference will not occur in a particular installation. If this equipment does cause harmful interference to radio or television reception, which can be determined by turning the equipment off and on, the user is encouraged to try to correct the interference by one or more of the following measures:

- Reorient or relocate the receiving antenna.
- Increase the separation between the equipment and receiver.
- Connect the equipment into an outlet on a circuit different from that to which the receiver is connected.
- Consult the dealer or an experienced radio/TV technician for help.

2. This device complies with Part 15 of the FCC Rules. Operation is subject to the following two conditions : (1) this device may not cause harmful interference, and (2) this device must accept any interference received, including interference that may cause undesired operation.

3. Shielded cables must be used with this unit to ensure compliance with the Class B FCC limits.